

# OceanAire

---

## AirBoss

Air-Cooled Portable  
Air Conditioners



## Polaris

Water-Cooled Portable  
Air Conditioners

# OceanAir

## AirBoss

### Air-Cooled Portable Air Conditioners

MODEL: PAC	1011	1211	1811	2412	3612	3632	3634	6012	6032	6034
Cooling Capacity <sup>1</sup>	10,100	12,700	18,010	24,020	36,050	36,050	36,050	60,050	60,050	60,050
Voltage (V/Phase) at 60Hz	115/1			208-230/1	208-230/1	208-230/3	460/3	208-230/1	208-230/3	460/3
Cooling Amps <sup>6</sup>	9.0	12.0	15.5	12.3	22.5	14.0	7.3	40.0	24.0	12.4
Cooling Watts <sup>6</sup>	1030	1256	1590	2200	3360	3360	3360	5900	5900	5900
In Rush Current (Amps)	69.9	92.8	114.2	79	128.8	111.8	111.8	198	134.2	135.6
Fuse/Breaker (Amps) <sup>2</sup>	15	15	20	20	30	20	20	50	30	20
Plug Type	5-15P	5-15P	5-20P	6-20P	6-30P	L15-20P	L16-20P	6-50P	L15-30P	L16-20P
EER <sup>3</sup>	10.6	10.1	11.3	10.9	10.7	10.7	10.7	10.1	10.1	10.1
Compressor HP	3/4	1	1 1/2	2	3	3	3	5	5	5
Compressor RLA	7.4	9.3	11.4	8.3	17.9	11.4	5.7	28	20	8.2
Compressor LRA	42	58	65	49	88	77	39	169	123	59.6
Evap CFM <sup>4</sup>	300	400	600	810	1310	1310	1310	1950	1950	1950
Evap Motor HP	1/15	1/15	1/5	1/3	1/2	1/2	1/2	1	1	1
Evap Motor Watts	200	200	210	350	375	375	375	550	550	550
Condenser CFM	580	580	930	1010	1390	1390	1390	2200	2200	2200
Condenser Motor HP	1/8	1/8	1/3	1	3	3	3	1	1	1
Condenser Motor Watts	280	280	450	330	460	460	460	750	750	750
Condensate Pump Head	5 Gallon Condensate Tank - STANDARD (20 ft with optional condensate pump kit)							20 ft (Pump -STANDARD)		
Sound Level <sup>5</sup>	53	54	60	65	69			78		
R-22 Charge Oz.	24	29	36	40	40			77		
(A) Height with Casters (in.)	31 1/2		37 1/2			47		52 1/4		
(B) Width (in.)	20 1/8		24 1/4			28 1/4				
(C) Depth (in.)	22 5/8		24 3/4			31		39		
(D) Height w/o Casters (in.)	28 1/2		34 1/2			42 1/4		48 3/4		
Net Weight (lb.)	150	150	200	210	280			460	460	520
Shipping Weight (lb.)	170	170	230	240	310			500	500	560
Shipping Volume (cu. ft.)	15		21			29		43		

Note: Condenser inlet air plenum adds 13 inches to dimension "C"

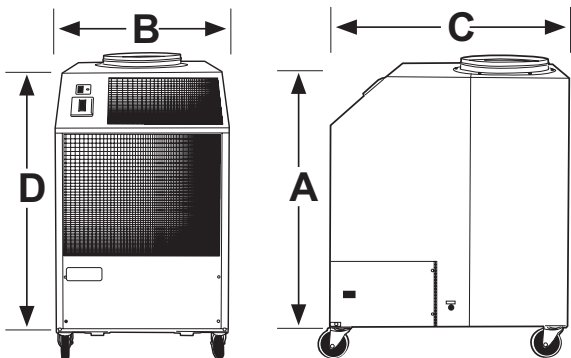

#### Specifications subject to change without notice

- Cooling Capacity is total BTU/HR at 80°DB/67°WB at high fan speed
- Time delay fuses/circuitbreakers are recommended.
- EER determined with condenser discharge air ducted into another area on high fan speed.
- CFM with free discharge.
- Sound Pressure, dB at 5 feet, commercial configuration.
- Amps & Watts at 208 Volts

#### Ambient operating range 65° to 105°

May operate to 55° if equipped with optional Factory installed hot gas bypass

All units available in 220/50 cycle

# OceanAire

## Polaris

### Water-Cooled Portable Air Conditioners

MODEL: PWC	1011	1211	1811	2412	3612	3632	3634	6012	6032	6034
Nominal Cooling Capacity <sup>1</sup>	10,500	13,780	18,840	23,950	36,100	36,100	36,100	60,100	60,100	60,100
Voltage ( Volts/Phase) at 60Hz	115/1			208-230/1		208-230/3	460/3	208-230/1	208-230/3	460/3
Unit Amps <sup>5</sup>	7.7	10.5	12.0	8.6	13.0	9.4	4.9	24.0	17.0	8.0
Unit Watts <sup>5</sup>	970	1050	1400	1990	3000	3000	3000	5350	5350	5350
In Rush Current (Amps)	69	79	92.6	64.6	109.6	103.4	80	183.1	134.2	130.6
Fuse/Breaker (Amps)	15	15	15	20	20	20	20	30	20	20
Plug Type	5-15P	5-15P	5-15P	6-20P	6-20P	L15-20P	L16-20P	6-30P	L15-20P	L16-20P
EER	12.1	13.1	13.5	12.3	12	12	12	11.3	11.3	11.3
Compressor HP	3	1	1 1	2	3	3	3	5	5	5
Compressor RLA	7.4	9.3	11.4	8.3	17.9	11.4	5.7	28	20	8.2
Compressor LRA	42	58	65	49	88	77	39	169	123	59.6
Evap CFM <sup>2</sup>	300	400	600	810	1310	1310	1310	1950	1950	1950
Evap Motor HP	1/15	1/15	1/8	1/3	1/3	1/3	1/3	1	1	1
Evap Motor Watts	200	200	210	350	375	375	375	550	550	550
Dimension E (in.)	18		21 1		29 1			32 3		
Dimension F (in.)	5 1		6		6			6		
Dimension G (in.)	3 1		4 1		4 1			4 1		
Cond Water Flow (GPM) at 60°F inlet	0.6	0.75	1.1	1.55	2.2	2.2	2.2	5.5	5.5	5.5
at 85°F inlet	2.5	3	4.5	6	9	9	9	15	15	15
Cond Coil Pressure Drop-PSI	0.2	0.4	0.4	0.2	0.4	0.4	0.4	0.4	0.4	0.4
Water Valve Pressure Drop PSI	2.0									
Water Valve Connection <sup>4</sup>	3/8 MF					5/8 MF				
Drain (Return) Connection	3/8 MF					5/8 MF				
Condensate Pump Head	20 Feet				3/8 MF Connection			All Units		
Sound Level <sup>3</sup>	48	52	57	60	62	62	62	69	69	69
R-22 Charge Oz.	18	19	22	24	36	36	36	46	46	46
(A) Height with Casters (in.)	31 1		37 1		4 7			52 1		
(D) Height Without Casters (in.)	28 1		34 1		42 1			46 1		
(B) Width (in.)	20 1/8		24 1		28 1					
(C) Depth (in.)	13 1/8		13		15 1			39		
Net Weight (lb.)	110	110	150	160	24 0			460	520	
Shipping Weight (lb.)	130	130	170	180	27 0			500	560	

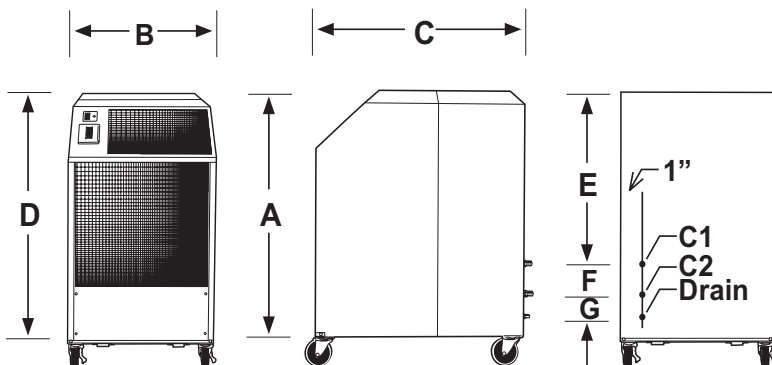

#### Water Connections

For PWC10 & PWC12

C1 = Water Out C2 = Water In

For PWC18,PWC24,PWC36 and PWC60

C1 = Water In C2 = Water Out

All units available in 220/50 cycle

#### Specifications subject to change without notice

<sup>1</sup> Nominal Capacity is total BTU/HR at 80°DB/67°WB return air with 85°EWT to 95°LWT (3GPM/Ton). Unit at high fan speed.

<sup>2</sup> CFM with free discharge.

<sup>3</sup> Sound Pressure, dB at 5 feet, commercial configuration.

<sup>4</sup> Size 3/8 M valve used on models 10,12,18,24 (with 3/8 M flare fitting) 3/4 valve used on model 36,60(with 5/8 M flare fitting)

<sup>5</sup> Amps & Watts at 208 Volts

**Ambient operating range 65° to 105°**  
May operate to 55° if equipped with optional Factory installed hot gas bypass



## PAC – AIR BOSS ACCESSORIES

### NOZZLE KIT

NK-1 (2 X 4-Inch) PAC10, 12  
 NK-2 (2 X 6-Inch) PAC18, 24, 36  
 NK-3 (2 X 8-Inch) PAC60



### EVAPORATOR RETURN AIR PLENUM

DEP-10 (10-Inch Round) PAC10, 12  
 DEP-12 (12-Inch Round) PAC18, 24, 36  
 DEP-16 (16-Inch Round) PAC60



### DISCHARGE DUCT ADAPTER

DDA-6 (6-Inch Round) PAC10, 12  
 DDA-10 (10-Inch Round) PAC18, 24, 36  
 DDA-16 (16-Inch Round) PAC60



## PWC – POLARIS ACCESSORIES

### NOZZLE KIT

NK-1 (2 X 4-Inch) PWC10, 12  
 NK-2 (2 X 6-Inch) PWC18, 24, 36  
 NK-3 (2 X 8-Inch) PWC60

### EVAPORATOR RETURN AIR PLENUM

DEP-10 (10-Inch Round) PWC10, 12  
 DEP-12 (12-Inch Round) PWC18, 24, 36  
 DEP-16 (16-Inch Round) PWC60

### DISCHARGE DUCT ADAPTER

DDA-6 (6-Inch Round) PWC10, 12  
 DDA-10 (10-Inch Round) PWC18, 24, 36  
 DDA-16 (16-Inch Round) PWC60

## PAC ONLY

### CONDENSATE PUMP KIT \*

PC-1P 115V Models  
 PC-2P 230V Models  
 \* Not Required for PAC60's



### CEILING PANEL KIT

CK-12 PAC10, 12, 18, 24, 36  
 CK-16 PAC60  
 CK-12PL CK-12 without Duct Flange  
 CKP-12 2 X 2 Ceiling Panel w/12-Inch Dia. Flange  
 CKP-16 2 X 2 Ceiling Panel w/16-Inch Dia. Flange



### DUCT FLANGE

DF-12 12-Inch Duct Flange  
 DF-16 16-Inch Duct Flange

### CONDENSER RETURN AIR PLENUM

DPC-1 PAC10, 12  
 DCP-2 PAC18, 24  
 DCP-3 PAC36  
 DCP-4 PAC60

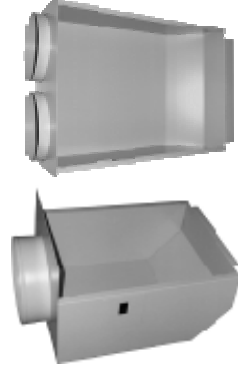

## PWC ONLY

### HOSE KIT

HK-1 10FT PWC10, 12, 18, 24  
 HK-2 25FT PWC10, 12, 18, 24  
 HK-5 40FT PWC10, 12, 18, 24  
 HK-3 10FT PWC36, 60  
 HK-4 25FT PWC36, 60  
 HK-6 40FT PWC36, 60



# OCEANAIRE

OCEANAIRE, Inc.  
 6228 Oakton Street  
 Morton Grove, IL 60053

Call: (847) 583-0311

Or Visit Us On the Web at: [www.oceanaire-inc.com](http://www.oceanaire-inc.com)

# PAC/PWC